

MFJ-407D/447
DELUXE ELECTRONIC KEYSER
with MEMORY

MANUAL

Introduction

The MFJ-407D Deluxe Electronic Keyer is a microprocessor controlled keyer that provides iambic key operation and dot-and-dash memory to make sending perfect code easier. It has tuneable code speed, code weight, and sidetone frequency; it supports both direct and grid-block keying outputs. You also get to choose between Iambic Type "A" and Type "B" keying.

Control Functions

1. The Power button turns the unit ON and OFF. The power is ON when the button is locked in the "in" position and OFF in the "out" position.
2. The Tune button continuously keys the transmitter for tuning.
3. The Semi-Auto/Auto button allows semi-automatic "bug" and manual operations. The keyer generates dots automatically when a squeeze or single lever key is used. Dashes are manually made. The keyer is completely manual when a straight key is used. Semi-Auto is active when the switch is in the "in" position and Auto when in the "out" position.
4. The Speed control varies the code speed. The speed range is configured with an internal jumper (JMP9) for 5 to 65 WPM or 10 to 40 WPM. Turn the control clockwise to increase speed and counter-clockwise to decrease speed. The unit is factory set to 5 to 65 WPM. To make the speed adjustment less sensitive, change the speed range to the narrower range of 10 to 40 WPM. To change the speed range the power must be off, then remove the cover by removing the two screws (one on each side) that secure it. Locate jumper JMP9 next to the microprocessor and set it to the "H" position.

Note: Power must be off when changing the jumper settings.

5. The Weight control varies the code weight from approximately 25 % to 75 %, with the standard dot defined as 50% weight. The standard dot-dashspace ratio is 1:3:1 (trimpot at mid-range). This control is turned clockwise to increase dot and dash lengths and counter-clockwise to decrease dot and dash lengths.
6. The Tone control sets the desired sidetone pitch from approximately 300 to 1200 Hz. This control is turned clockwise to raise the pitch and counterclockwise to lower the pitch.
7. The Volume control adjusts the sidetone level of the internal speaker. Turn the control clockwise to increase the volume and counter-clockwise to decrease the volume.
8. The Direct/Grid-Block Output keying circuit allows keying of grid-block and solid state transmitters. The MFJ-407D can only key one type of transmitter at a time. This is an internal jumper selected option. The unit is factory set to direct keying. To change to grid-block keying the power must be off, then remove the cover by removing the two screws (one on each side) that secure it. Locate JMP1 and JMP2. JMP2 is directly behind the RCA jack and JMP1 is approximately one inch in front of JMP2. Set both jumpers JMP1 and JMP2 to the "G" position. To key a solid state transmitter, set both jumpers to the "D" position.

Note: Power must be off when changing the jumper settings.

9. The Iambic Type A/B mode is also set inside the unit with a jumper. The unit is factory set for Type "A" Iambic. If you prefer Type "B" Iambic, remove the cover by removing the two screws (one on each side) that secure it. Locate jumper JMP3 and set it to the "B" position. For Type "A" Iambic, set the jumper to the "A" position.

Note: Power must be off when changing the jumper settings.

When a squeeze is released during an element (dot or dash), type "B" adds the opposite element. Type "A" just finishes the element in progress and does not produce a following alternate element. For example, in Type "A" Iambic, a squeeze release during the "dah" in the letter A will produce "didah" (A). In Type "B" Iambic, a squeeze release during the "dah" in the letter A will produce "di-dah-dit" (R).

Installation

1. A 9-volt battery (not included) may be installed. Remove the cover by removing the two screws (one on each side) that secure it.. A battery holder, located inside the enclosure, is provided for installing a 9-volt battery.
2. A 12 VDC power supply may also be used to power the MFJ-407D. A 2.1mm coaxial plug with a positive center and a negative sleeve should be used to power this unit. The MFJ-1312B, an optional 12 volts adapter, is available from MFJ Enterprises, Inc. The battery is automatically disconnected when external power is used.
3. A squeeze or single lever key can be used. Squeeze key allows Iambic operation. A 1/4-inch stereo phono plug and a two-conductor shielded cable should be used. If separate shielded cables are used, the two shields should be tied together and connected to ground. The dot wire should be connected to the tip of the plug and the dash wire to the ring. The MFJ-407D becomes a manual keyer when a straight key is used. The unit will safely key your transmitter and eliminate the shock hazard of high voltage being present on the straight key.

Note: To use a straight key, first switch the keyer to the Semi-Auto mode (button in). Again a 1/4-inch stereo phono plug should be used because a mono plug will not work on a straight key in Semi-Auto mode. Connect one wire to the ring of the plug and another wire to ground. The tip of the plug should not be used.

4. Output keying circuit allows keying of grid-block and solid state transmitters. Remember this is internally jumper selected (refer to page 2). The keying output connection is made with a RCA phono plug. Note: Consult the transmitter's instruction manual to determine which output to use. When in doubt, try both jumper positions. The transmitter will key continuously when the jumpers are connected to the wrong positions.

Keyer Operation

1. A 9-volt battery or an optional DC-adapter may be used to supply power to the keyer.
2. The key paddle should be connected to the Key jack on the rear panel of the unit. A dual paddle squeeze key or a single lever key can be used.
3. An external speaker can be connected to the Speaker jack on the rear panel of the unit.
4. Next, the keyer should be turned on with the Power switch.
5. The Semi-Auto/Auto switch should be in the "out" position for automatic operation.
6. The user should now start sending with the paddle and adjust volume, tone, weight, and speed to his or her preference.
7. The dot and dash memories make sending easier. The memories allow the user to key a dot before the completion of a dash and vice versa. This feature can be checked by setting the keyer to the lowest speed and tapping first the dash lever and then the dot lever before the completion of the dash. The keyer will provide both the dash and the dot. The dash memory can be checked in a similar manner. The dot insertion feature allows the user to insert a dot by tapping the dot lever while holding the dash lever in. The dash insertion feature allows the user to insert a dash while holding the dot lever in. The Iambic operation allows sending of alternate dots and dashes when using squeeze key and with both paddles squeezed. The first paddle contacted will determine whether a dot or dash occurs first.
8. The user may select either Iambic A or B according to his preference.

Jumper Settings

JMP1	JMP2	JMP3	JMP9	
D	D			Keying Mode Direct *
D	G			Invalid
G	D			Invalid
G	G			Keying Mode Grid Block
		A		Iambic Mode A *
		B		Iambic Mode B
			L	Speed Range 5 – 66 WPM *
			H	Speed Range 10 – 40 WPM

* Factory default

Morse Code Character Set ¹

A di-dah	..	N dah-dit	--	
B dah-di-di-dit	O dah-dah-dah	---	
C dah-di-dah-dit	P di-dah-dah-dit	
D dah-di-dit	...	Q dah-dah-di-dah	----	
E dit	.	R di-dah-dit	...	
F di-di-dah-dit	S di-di-dit	...	
G dah-dah-dit	--	T dah	-	
H di-di-di-dit	U di-di-dah	...	
I di-dit	..	V di-di-di-dah	
J di-dah-dah-dah	----	W di-dah-dah	---	
K dah-di-dah	---	X dah-di-di-dah	----	
L di-dah-di-dit	Y dah-di-dah-dah	----	
M dah-dah	--	Z dah-dah-di-dit	
1 di-dah-dah-dah-dah	-----	6 dah-di-di-di-dit	
2 di-di-dah-dah-dah	-----	7 dah-dah-di-di-dit	-----	
3 di-di-di-dah-dah	-----	8 dah-dah-dah-di-dit	-----	
4 di-di-di-di-dah	-----	9 dah-dah-dah-dah-dit	-----	
5 di-di-di-di-dit	0 dah-dah-dah-dah-dah	-----	
Period [.] di-dah-di-dah-di-dah	-----			<u>AAA</u>
Comma [,] dah-dah-di-di-dah-dah	-----			<u>MIM</u>
Question Mark or Request for Repetition [?] di-di-dah-dah-di-dit			<u>IMI</u>
Fraction Bar or Slash Bar [/] dah-di-di-dah-dit			<u>DN</u>
End of Message, Plus Sign, or Cross [+] di-dah-di-dah-dit			<u>AR</u>
End of Work di-di-di-dah-di-dah	-----			<u>SK</u>
Double Dash, Equal Sign, Pause, or Break [=] dah-di-di-di-dah	-----			<u>BT</u>
Semicolon [;] dah-di-dah-di-dah-dit	-----			<u>KR</u>
Colon [:] dah-dah-dah-di-di-dit	-----			<u>OS</u>
Apostrophe ['] di-dah-dah-dah-dah-dit	-----			<u>WG</u>
Quotation Mark ["] di-dah-di-di-dah-dit	-----			<u>AF</u>
Hyphen or Dash [-] dah-di-di-di-di-dah	-----			<u>DU</u>
Underline [_] di-di-dah-dah-di-dah	-----			<u>IQ</u>
Dollar Sign [\$] di-di-di-dah-di-di-dah	-----			<u>SX</u>
Left Parenthesis or Go Only [(] dah-di-dah-dah-dit	-----			<u>KN</u>
Right Parenthesis [)] dah-di-dah-dah-di-dah	-----			<u>KK</u>
Wait or Stand By di-dah-di-di-dit			<u>AS</u>
Understood di-di-di-dah-dit			<u>SN</u>
Starting Signal dah-di-dah-di-dah	-----			<u>KA</u>
Error di-di-di-di-di-di-dit			<u>HH</u>
Paragraph [¶] di-dah-di-dah-di-dit	-----			<u>AL</u>
Invitation to Transmit or Go Ahead [K] dah-di-dah	---			K

Signals used in other Radio Services

Interrogatory di-di-dah-di-dah	-----	<u>INT</u>
Emergency Silence di-di-di-di-dah-dah	-----	<u>HM</u>
Executive Follows di-di-dah-di-di-dah	-----	<u>IX</u>
Break-in Signal dah-dah-dah-dah-dah	-----	<u>TTTTT</u>
Emergency Signal di-di-di-dah-dah-dah-di-di-dit	-----	<u>SOS</u>
Relay of Distress dah-di-di-dah-di-di-dah-di-dit	-----	<u>DDD</u>

¹ FCC test requirement consists the 26 letters, the 10 numerals, the period, the comma, the question mark, AR, SK, BT and fraction bar DN.

Technical Assistance

If you have any problem with this unit first check the appropriate section of this manual. If the manual does not reference your problem or your problem is not solved by reading the manual you may call MFJ Technical Service at 601-3230549 or the MFJ Factory at 601-323-5869. You will be best helped if you have your unit, manual and all information on your station handy so you can answer any questions the technicians may ask.

You can also send questions by mail to MFJ Enterprises, Inc., 300 Industrial Park Road, Starkville, MS 39759; by Facsimile to 601-323-6551; or by eMail to techinfo@mfjenterprises.com. Send a complete description of your problem, an explanation of exactly how you are using your unit, and a complete description of your station.

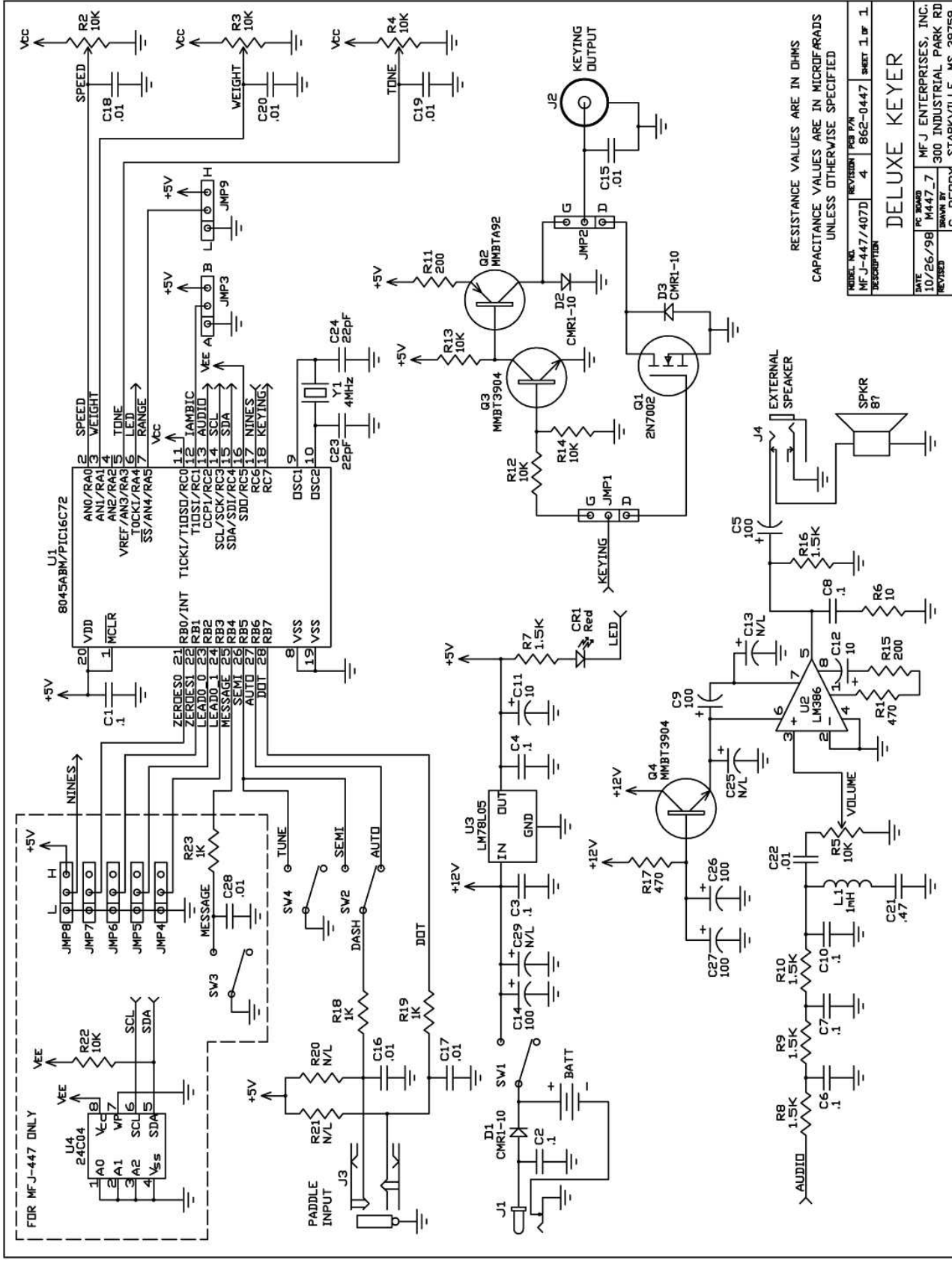

RESISTANCE VALUES ARE IN OHMS
CAPACITANCE VALUES ARE IN MICROFARADS
UNLESS OTHERWISE SPECIFIED

FORM NO.	REVISED	REV. NO.	DESCRIPTION
MFJ-447/407D		4	862-0447 SHEET 1 OF 1
PC BOARD	DATE	DESIGNED BY	
M447-7	10/26/98	C. PERRY	
DRAWN BY			MFJ ENTERPRISES, INC.
REVISED			300 INDUSTRIAL PARK RD
			STARKVILLE, MS 39759

DELUXE KEYSER

FOR MFJ-447 ONLY