



**MFJ-422B/422B-X  
ELECTRONIC KEYS PADDLE**

**OWNER'S MANUAL**

**CAUTION: Read All Instructions Before Operating Equipment.**

**MFJ ENTERPRISES, INC.**

**P. O. BOX 494, MISSISSIPPI STATE, MS. 39762, USA**

© MFJ ENTERPRISES, INC.

# MFJ-422B/422B-X INSTRUCTIONS

## INTRODUCTION

Thank you for your purchase of the MFJ-422B/422B-X Electronic Keyer. The MFJ-422B/422B-X is designed to mount on the *BENCHER*-paddle resulting in a compact, one-piece Keyer/Paddle combination. The improved Curtis 8044 ABM Keyer IC is used in the MFJ-422B/422B-X to make perfect code transmission easy and pleasant. Controls are located for easy access while operating.

## CONTROLS

1. VOLUME: Adjust the volume of the sidetone from the internal speaker. Functions as the power ON/OFF switch for the MFJ-422B/422B-X.
2. SPEED: Varies the sending speed from 8 to 50 WPM.
3. AUTO/SEMI-AUTO: AUTO-Normal operating position. Dots and dashes of the correct length are generated automatically.  
SEMI-AUTO:-Dots are generated automatically. Dashes are manually made. (NOTE: In this position, when the dash paddle is held your transmitter is continuously for tuning.)
4. tone: Sets the pitch of the sidetones. This control is recessed inside the cabinet between the VOLUME and SPEED controls. A small flat head screwdriver is needed for adjustment.
5. WEIGHT: Adjusts dot and dash lengths. When turned fully counter-clockwise, dot-dash-space ratio is a perfect 1:3:1. This control is located on the rear of the cabinet and is also recessed. A small flat head screwdriver is necessary for adjustment. (NOTE: The weight control is factory set for a 1:3:1 ratio.)

## INSTALLATION

### FOR MFJ-422B (KEYER WITH PADDLE)

If you purchased the MFJ-422B (Keyer with Paddle), the keyer will come factory installed on the paddle and the only connections necessary will be to your transmitter and power supply if used.

If battery operation is desired, remove the rubber foot on the bottom rear of the paddle and screw holding the plastic wire clamp from the bottom center of the paddle. The keyer will now slide off the paddle base toward the rear. Install a 9V transistor battery in the battery snap and slip the battery into the holder. Reverse the above procedure to re-install the keyer onto the paddle. Feed the connecting cable through the slot on the bottom of the paddle and is clamped securely with the cable clamp. (NOTE: Long-life Alkaline type batteries are recommended for longest uninterrupted operation.)

### **FOR MFJ-422B-X (KEYER WITHOUT PADDLE)**

If you purchased the MFJ-422B-X (Keyer without Paddle) for connection to your own *BENCHER*-paddle, follow the procedure below for proper connection.

1. Remove the rubber foot from the bottom rear of your *BENCHER*-paddle.
2. Remove the plastic cable clamp from the bottom center of the paddle.
3. Solder the shield on the cable from the MFJ-422B-X to the solder lug located between the rear rubber foot and the cable clamp on the bottom of the paddle.
4. Solder the red wire in the cable from the MFJ-422B-X to the solder lug on the dot post of the paddle and the white wire to the solder lug on the dash post.
5. If battery operation is desired, install a 9 V transistor battery in the battery snap in the MFJ-422B-X and slip the battery into the battery holder. (NOTE: Long-life Alkaline type batteries are recommended for the longest uninterrupted operation.)
6. Replace the screw holding the rear rubber foot on the paddle with the 4-40 × 3/8" screw supplied with the MFJ-422B-X.
7. The MFJ-422B-X can now be slid onto the *BENCHER*-paddle from the rear. Feed the cable through the slot in the bottom right rear of the box. Secure the box to the paddle by remounting the rear rubber foot through the box to the paddle base. Fold the cable up neatly and secure with the plastic cable clamp on the bottom of your *BENCHER*-paddle.

### **TRANSMITTER CONNECTION** **(MFJ-422B/422B-X)**

1. Provision is made for powering the MFJ-422B/422B-X with external 5-9V DC supply. A subminiature POWER jack is located on the rear of the MFJ-422B/422B-X for this purpose. An optional AC adapter is available from the MFJ Enterprises, Inc. When a plug is inserted into the POWER jack, the battery is automatically disconnected. Use an adapter with a 2.5 mm phone plug with the tip being positive.
2. Connect a shielded cable from the KEYING OUTPUT of the MFJ-422B/422B-X to your transmitter. Consult the instructions for your transmitter to determine whether to use the "Direct" or "Grid block" output jack. (NOTE: If in doubt as to which jack to use, try both jacks. If the transmitter keys continuously when the cable is plugged into one jack, use the other one.)

## **OPERATION**

After proper connection of the MFJ-422B/422B-X you are ready for operation. Rotate the VOLUME control clockwise to turn power on as indicated by the LED light. Start sending with the paddle and adjust the VOLUME, SPEED, TONE, and WEIGHT controls to your preference. (NOTE: If a steady tone at high speed occurs, reduce the WEIGHT or the SPEED by turning the respective control counter-clockwise.)

The dot and dash memory feature of the Curtis 8044 ABM-IC makes sending easier. This feature allows keying a dot before completion of a dash or vice versa. This feature can be checked by setting the keyer to the lowest speed and tapping first the dash paddle and then the dot paddle before of the dash. The dash memory can be checked in a similar manner. The dot insertion feature allows you to tap the dot paddle while holding in the dash paddle. A dot will be insert automatically. The dash insertion feature allows you to insert a dash while holding in the dot paddle. With both paddles squeezed, the IAMBIC operation feature allows sending of alternate dots and dashes. First paddle contact determine whether a dot or a dash occurs first.

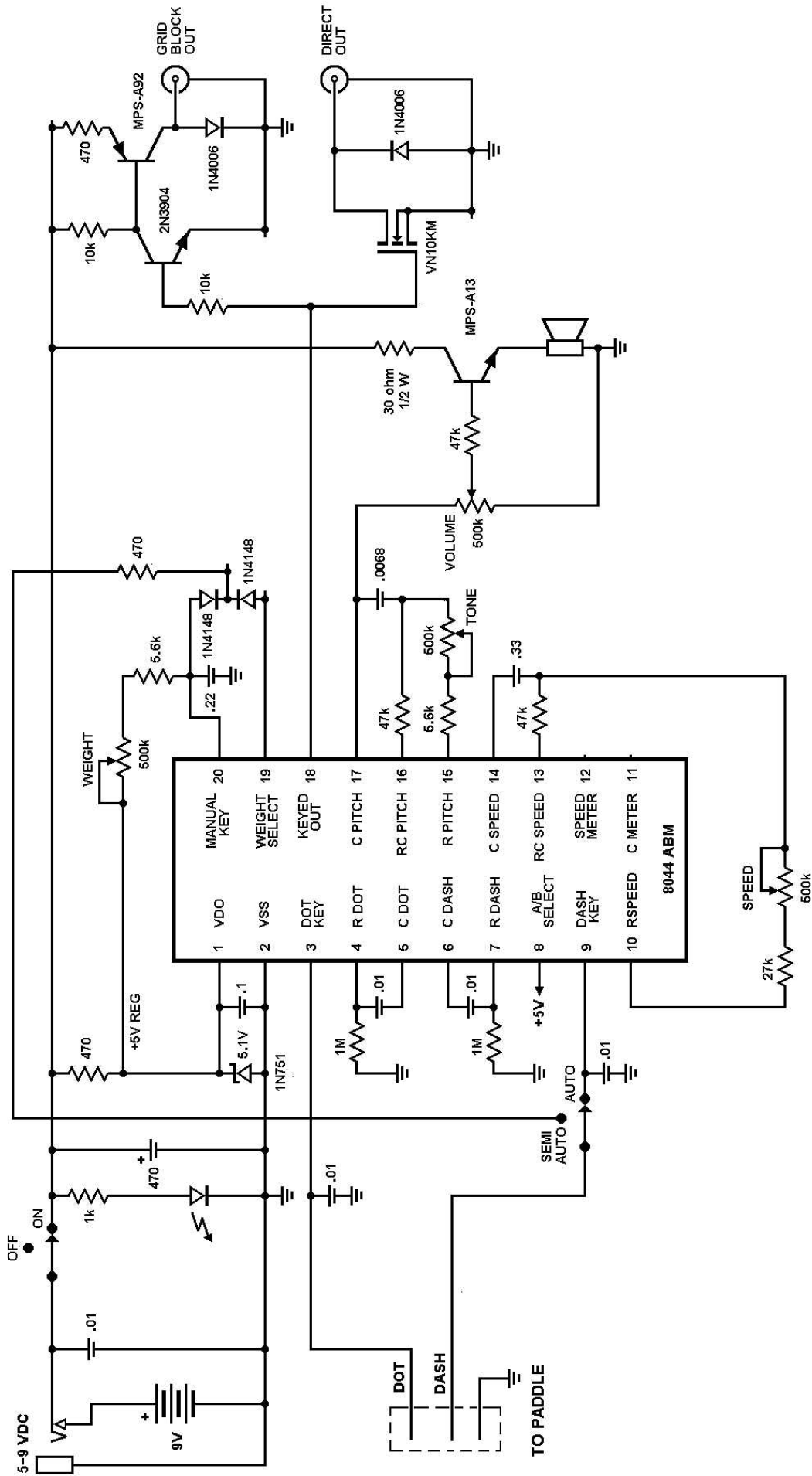

**MFJ-422B/422B-X SCHEMATIC DIAGRAM**