



**MFJ-422E / 422EX**  
**Electronic Keyer Paddle**  
**with Memory**

## Introduction

The MFJ-422E Electronic Keyer Paddle with Memory is an iambic keyer and paddle combination. The MFJ-422EX keyer installs on your MFJ-564 or Bencher type paddle. Both are microprocessor controlled keyers that provide iambic key operation and dot-and-dash memory to make sending perfect code easier. It has tunable code speed, code weight, and sidetone frequency; it supports both direct and grid-block keying outputs. You also get to choose between Iambic Type "A" and Type "B" keying. It even has a non-volatile memory to record and play a message of your choice.

*Note: All references to the MFJ-422E apply to the MFJ-422EX, unless otherwise stated.*

## Control Functions

1. The **Power** button turns the unit ON and OFF. The power is ON when the button is locked in the "in" position and the LED is lit and OFF in the "out" position.
2. The **Semi-Auto/Auto** button allows semi-automatic "bug" and manual operations. The keyer generates dots automatically when a squeeze or single lever key is used. Dashes are manually made. The keyer is completely manual when a straight key is used. Semi-Auto is active when the switch is in the "in" position and Auto when in the "out" position.
3. The **Message** button lets you record and play a message from the non-volatile memory. It is a momentary push-button that is time sensitive.
4. The **Speed** control, located on the left side of the unit, varies the code speed. The speed range is configured with an internal jumper (JMP9) for 5 to 65 WPM or 10 to 40 WPM. Turn the control clockwise to increase speed and counter-clockwise to decrease speed. The unit is factory set to 5 to 65 WPM. To make the speed adjustment less sensitive, change the speed range to the narrower range of 10 to 40 WPM. To change the speed range the power must be off, then remove the paddle to access the jumper inside the case. Locate jumper JMP9 next to the microprocessor and set it to the "H" position.

*Note: Power must be off when changing the jumper settings.*

5. The **Volume** control, located on the left side of the unit, adjusts the sidetone level of the internal speaker. Turn the control clockwise to increase the volume and counter-clockwise to decrease the volume.
6. The **Weight** control varies the code weight from approximately 25 % to 75 %, with the standard dot defined as 50% weight. The standard dot-dash-space ratio is 1:3:1 (trimpot at mid-range). This control is accessed through a small hole on the rear of the unit and may be adjusted using a small flatheaded screwdriver. This control is turned clockwise to increase dot and dash lengths and counter-clockwise to decrease dot and dash lengths.
7. The **Tone** control sets the desired sidetone pitch from approximately 300 to 1200 Hz. This control is also accessed through a small hole on the rear of the unit and may be adjusted using a small flat-headed screwdriver. This control is turned clockwise to raise the pitch and counter-clockwise to lower the pitch.
8. The **Key Output** circuit supports both positive and negative keyed radios. The MFJ-422E can only key one type of transmitter at a time. This is an internal jumper selected option. The unit is factory set to direct keying (most solid state radios). To change to grid-block keying (most radios with tube finals) the power must be off, then remove the paddle to access the jumpers inside the case. Locate jumpers JMP1 and JMP2. JMP2 is directly behind the RCA jack (J2).

JMP1 is located behind the power jack (J1). Set both jumpers JMP1 and JMP2 to the "G" position. To key a solid state transmitter, set both jumpers to the "D" position.

*Note: Power must be off when changing the jumper settings.*

9. The **Iambic Type A/B** mode is also set inside the unit with a jumper. The unit is factory set for Type "A" Iambic. If you prefer Type "B" Iambic, remove the paddle to access the jumper. Locate jumper JMP3 behind the power jack (J1), between JMP1 and JMP8; set it to the "B" position. For Type "A" Iambic, set the jumper to the "A" position.

*Note: Power must be off when changing the jumper settings.*

When a squeeze is released during an element (dot or dash), type "B" adds the opposite element. Type "A" just finishes the element in progress and does not produce a following alternate element. For example, in Type "A" Iambic, a squeeze release during the "dah" in the letter A will produce "dit dah" (A). In Type "B" Iambic, a squeeze release during the "dah" in the letter A will produce "dit dah dit" (R).

### **Paddle Installation for the MFJ-422EX**

If you purchased the MFJ-422EX (keyer without paddle), you must install it onto your paddle. Follow these instructions for installing the MFJ-422EX onto a MFJ-564 or Bencher type paddle:

1. Remove any cables from the paddle. Do not apply power to unit while it is disassembled.
2. Set up your MFJ-422EX now, using the nine internal jumpers, to the type of output keying required, the desired Iambic mode, the speed range, and the format of the serial number. Refer to the "Jumper Settings" section on page 7 for the meanings of these jumpers.
3. If you wish to use a nine volt battery, install one now. A nine volt battery fits in the battery clip located inside the case. MFJ suggests the use of a good long-life alkaline battery for longest operation.
4. Remove the rubber foot from the bottom rear of the paddle.
5. Remove the plastic cable clamp from the bottom center of the paddle.
6. Slide the MFJ-422EX on to the back of the paddle. Thread the cable through the slot on the bottom of the MFJ-422EX. Secure the case with the rubber foot and new screws. The MFJ-564 Iambic Paddle has four additional holes to better secure the case of the paddle.
7. Connect the BARE wire of the cable to the middle terminal on the bottom of the paddle for GROUND.
8. If you normally operate the paddle right-handed, then connect the DOT (white or clear colored) wire to the left paddle terminal and the DASH (black) wire to the right terminal. Connect the wires the opposite way if you operate the paddle left-handed.
9. Place the cable in the plastic cable clamp and secure it with a screw. Fold any excess cable up into the unit.

## Connections

1. A nine volt battery (not included) may be installed. Remove the case by removing the screws on the bottom that secure it to the paddle. A battery clip, located inside the case, is provided for installing a nine volt battery.
2. A 12 VDC power supply may also be used to power the MFJ-422E. A 2.1 mm coaxial plug with a positive center and a negative sleeve should be used to power this unit. The MFJ-1312D, an optional power adapter, is available from MFJ Enterprises, Inc. The battery is automatically disconnected when external power is used.
3. The keying circuit allows keying of grid-block and solid state transmitters. Keying output connection is made with a quality standard shielded RCA cable between your radio key input and the MFJ-422E's Key Output jack. Note: Consult the transmitter's instruction manual to determine which output to use. When in doubt, try both jumper positions. The transmitter will key continuously or not at all when the jumpers are connected to the wrong positions.

## Keyer Operation

1. A nine volt battery or an optional power adapter may be used to supply power to the keyer.
2. The keyer should be turned on by pressing the Power button and the LED is lit.
3. The Semi-Auto/Auto button should be in the "out" position for automatic operation.
4. The user should now start sending with the paddle and adjust volume, tone, weight and speed to his or her preference.
5. The dot and dash memories make sending easier. The memories allow the user to key a dot before the completion of a dash and vice versa. This feature can be checked by setting the keyer to the lowest speed and tapping first the dash lever and then the dot lever before the completion of the dash. The keyer will provide both the dash and the dot. The dash memory can be checked in a similar manner. The dot insertion feature allows the user to insert a dot by tapping the dot lever while holding the dash lever in. The dash insertion feature allows the user to insert a dash while holding the dot lever in. The Iambic operation feature allows sending of alternate dots and dashes when both paddles are squeezed. The first paddle contacted will determine whether a dot or dash occurs first.
6. The user may select either Iambic A or B according to his or her preference.

## Message Memory

The Message button is used to record and play your message. To record the message, press and hold the Message button until the keyer plays "GO" (dah-dah-dit dah-dah-dah) in Morse code and the LED flashes. You may now key in the message of your choice. As you pause after every word, the keyer will play a "W" (di-dah-dah) over the sidetone speaker to show that it is inserting a word break (uses one unit of memory). If you make a mistake entering a word, you can back up over it by briefly pressing and releasing the Message button. The keyer will erase the last word, then play the word before it (if any) to let you know where you stopped. If deleting the first word of the message, the keyer will play "GO" instead. At the end of your message, press and hold the Message button until the keyer sends an end of message character "+" (di-dah-di-dah-dit) and the LED stops flashing. When there are ten or less units of memory remaining, the LED will flash faster to let you know the memory is running low. If you try to save more characters than you have

memory, the keyer will automatically end your message and send you an end of message character. The speed, weight and tone cannot be changed during message recording. Also, the output keying circuit is disabled during recording.

*Note: A straight or manual key cannot be used to record the message.*

To play the recorded message, momentarily press the Message button. Ongoing message can be stopped by tapping either paddle or pressing the Message button.

The non-volatile memory is set up for only one message. There are 507 units of memory, which can record up to 507 characters (nine elements maximum per character--an element is a dot or a dash). Each normal character uses one unit of memory; only the rarely used 7-, 8- and 9-element characters require two units of memory.

### **Embedded Commands:**

While in the message recording mode you may use embedded commands for special features. To use an embedded command simply store the multicharacter embedded command code within your message.

**/D** Decrement--decrements the serial number. Serial number 0001 will decrement to 9999, skipping 0000 since it is not used. This feature allows a serial number to be sent twice in a message.

Example: UR RST 559 559 SN /N /D SN /N

**/G#** Gap--inserts a gap of # standard intra-character spaces into the message, where # is a digit in the range of 1 to 9 (0 can be used but not practical). Invalid numeral code will automatically default to zero. This command is used to exaggerate inter-character and word spacing.

**/L** Loop--creates a message loop (message repeat). Note that any character recorded after "/L" will not be sent.

Example: BEACON AA5CS 5 W /L

**/N** Number--inserts a contest serial number, in the range of 001 to 9999, into the message. Jumpers JMP4 to JMP8 controls the way zeros and nines in the serial number are sent. Only three digits are sent for numbers less than 1000 – use leading zeros when appropriate. The serial number is automatically post-incremented each time it is sent and updated in the non-volatile memory. Serial number 9999 will wraparound to 0001, skipping 0000 since it is not used. The serial number is set to the same one as before when power on. If a different serial number is desired, it must be programmed during power up. To initialize the serial number, press and hold the Message button while turning the power on until the keyer plays "GO" (dah-dah-dit dah-dahdah) and the LED flashes. You must then enter four numbers in Morse code for a valid serial number, most-significant digit first (invalid numeral code will automatically convert to zero). All numbers must be in the proper Morse code format. For example, the number "1" must be "di-dah-dah-dah-dah" and the number "0" must be "dah-dah-dah-dah-dah". When four numbers are entered, the keyer will automatically send an end of message character "+" (di-dah-di-dah-dit). The keyer then resumes with normal operation when the LED stops flashing. The serial number can be set from 0000 to 9999 (0000 will automatically convert to 0001).

Example: YOU ARE CONTACT NR /N

**/Pmmss** Pause-inserts a timed pause of mm minutes and ss seconds into the message. Four numbers must follow "/P". Invalid numeral code will automatically default to zero.

Example: TIMEOUT 1 HOUR /P6000 TIMEOUT 1.5 MIN /P0090 TIMEOUT 1 HR 40 MIN 39 SEC /P9999

**/R** Resume-suspends message playback to allow insertion of paddle entry. Once paddle sending is finished, press the Message button again to continue the message.

**/S** Space-inserts an extra standard word space into the message. This command yields the same result as "/G7" but uses one less unit of memory.

**//** Slash character-stores the slash character "/" into the message.

## Jumper Settings

JMP1	JMP2	Keying Mode
D	D	Direct *
D	G	Invalid
G	D	Invalid
G	G	Grid Block
JMP3		Iambic Mode
A		A *
B		B
JMP4	JMP5	Leading Zeros
L	L	none
L	H	0
H	L	O *
H	H	T
JMP6	JMP7	Other Zeros
L	L	0 *
L	H	0
H	L	O
H	H	T
JMP8		Nines
L		9 *
H		N
JMP9		Speed Range
L		5 – 65 WPM *
H		10 – 40 WPM

\* Factory defaults.

## Self Test

A self test is included to perform testing of the paddle, the buttons, the controls, and the audio circuitry. At any time, turn off the power to stop the self test.

To perform this test:

1. Turn off the power and remove the power plug.
2. Push all buttons so they are in the out position.
3. Turn all knobs to full clockwise position, except the Volume control. Set volume to a comfortable listening level.
4. Remove the case by removing the screws on the bottom that secure it to the paddle.
5. Remove jumpers JMP4 to JMP7. Set jumper JMP3 to the "B" position. Set jumpers JMP8 and JMP9 to the "H" position.
6. Reconnect power.
7. Squeeze the paddle while turning the power on. The self test starts by sending the copyright message "COPYRIGHT 1996-XXXX MFJ ENTERPRISES, INC. VERSION X.XX" confirming the audio circuitry is working properly. Release the paddle before the message is finished. For the entire test, the LED should blink once after each operation. If the LED blinks continuously the unit fails the test and a Morse code message is sent to indicate the nature of the failure.
8. The paddle, the buttons, and jumpers JMP3 to JMP9 are automatically tested for shorts to ground. The LED should be off at this point.
9. Press and release the dot level; press and release the dash level.
10. Press and release the Message button.
11. Lock in the Semi-Auto/Auto button, then press and release the dash level.
12. Test the Speed control by turning it to full counter-clockwise then to full clockwise. The LED should blink once at each end.
13. Test the Weight and Tone controls in the same way. The LED should blink once at each end.
14. Test the jumper connections by placing the plug-in jumpers on the "A" position of JMP3 and the "L" positions of JMP4 to JMP9 in ascending order. The LED should blink once for each jumper.
15. When all is okay, a repetitive message "PASS" is sent to the speaker. A repetitive message such as "SP FAIL" indicates that you did not follow the correct order or the unit failed the test.
16. Turn off the power after confirming the audio has good quality and remove the power plug.
17. Replace all jumpers to their original positions.
18. Replace the case on to the paddle and secure it with the screws.
19. Reconnect power and resume with normal operation.

## Memory Test

A test is also included to perform testing of the non-volatile memory (EEPROM) circuitry. This procedure can also be used to reset the contest serial number to 0001.

To test the non-volatile memory:

1. Turn off the power.
2. Press and lock in the Semi-Auto/Auto button.
3. Squeeze the paddle while turning the power on.
4. The non-volatile memory circuitry is then automatically tested. Notice this step resets the serial number to 0001.
5. If the non-volatile memory is okay, "EE PASS" is sent repetitively. If something is wrong, "EE FAIL" is sent repetitively.
6. Turn off the power.

Failure Message Meanings:

- DH FAIL Dash level is shorted or improperly connected.
- DT FAIL Dot level is shorted or improperly connected.
- EE FAIL Non-volatile memory circuitry is improperly connected.
- J3 FAIL Jumper JMP3 is shorted or improperly connected.
- J4 FAIL Jumper JMP4 is shorted or improperly connected.
- J5 FAIL Jumper JMP5 is shorted or improperly connected.
- J6 FAIL Jumper JMP6 is shorted or improperly connected.
- J7 FAIL Jumper JMP7 is shorted or improperly connected.
- J8 FAIL Jumper JMP8 is shorted or improperly connected.
- J9 FAIL Jumper JMP9 is shorted or improperly connected.
- MG FAIL Message button is shorted or improperly connected.
- SA FAIL Semi-Auto/Auto button is shorted or improperly connected.
- SP FAIL Speed control is bad.
- TN FAIL Tone control is bad.
- WT FAIL Weight control is bad.



**Morse Code Character Set <sup>1</sup>**

A di-dah	..	N dah-dit	--
B dah-di-di-dit	....	O dah-dah-dah	---
C dah-di-dah-dit	....	P di-dah-dah-dit	....
D dah-di-dit	...	Q dah-dah-di-dah	----
E dit	.	R di-dah-dit	...
F di-di-dah-dit	....	S di-di-dit	...
G dah-dah-dit	---	T dah	-
H di-di-di-dit	....	U di-di-dah	...
I di-dit	..	V di-di-di-dah	....
J di-dah-dah-dah	----	W di-dah-dah	---
K dah-di-dah	---	X dah-di-di-dah	----
L di-dah-di-dit	....	Y dah-di-dah-dah	----
M dah-dah	--	Z dah-dah-di-dit	----
1 di-dah-dah-dah-dah	-----	6 dah-di-di-di-dit	.....
2 di-di-dah-dah-dah	-----	7 dah-dah-di-di-dit	-----
3 di-di-di-dah-dah	-----	8 dah-dah-dah-di-dit	-----
4 di-di-di-di-dah	-----	9 dah-dah-dah-dah-dit	-----
5 di-di-di-di-dit	.....	0 dah-dah-dah-dah-dah	-----
Period [.] di-dah-di-dah-di-dah	-----		<u>AAA</u>
Comma [,] dah-dah-di-di-dah-dah	-----		<u>MIM</u>
Question Mark or Request for Repetition [?] di-di-dah-dah-di-dit	.....		<u>IMI</u>
Fraction Bar or Slash Bar [/] dah-di-di-dah-dit	-----		<u>DN</u>
End of Message, Plus Sign, or Cross [+] di-dah-di-dah-dit	-----		<u>AR</u>
End of Work di-di-di-dah-di-dah	-----		<u>SK</u>
Double Dash, Equal Sign, Pause, or Break [=] dah-di-di-di-dah	-----		<u>BT</u>
Semicolon [;] dah-di-dah-di-dah-dit	-----		<u>KR</u>
Colon [:] dah-dah-dah-di-di-dit	-----		<u>OS</u>
Apostrophe ['] di-dah-dah-dah-dah-dit	-----		<u>WG</u>
Quotation Mark ["] di-dah-di-di-dah-dit	-----		<u>AF</u>
Hyphen or Dash [-] dah-di-di-di-di-dah	-----		<u>DU</u>
Underline [_] di-di-dah-dah-di-dah	-----		<u>IQ</u>
Dollar Sign [\$] di-di-di-dah-di-di-dah	-----		<u>SX</u>
Left Parenthesis or Go Only [(] dah-di-dah-dah-dit	-----		<u>KN</u>
Right Parenthesis [)] dah-di-dah-dah-di-dah	-----		<u>KK</u>
Wait or Stand By di-dah-di-di-dit	-----		<u>AS</u>
Understood di-di-di-dah-dit	-----		<u>SN</u>
Starting Signal dah-di-dah-di-dah	-----		<u>KA</u>
Error di-di-di-di-di-di-dit	.....		<u>HH</u>
Paragraph [¶] di-dah-di-dah-di-dit	-----		<u>AL</u>
Invitation to Transmit or Go Ahead [K] dah-di-dah	---		K

<sup>1</sup> FCC test requirement consists the 26 letters, the 10 numerals, the period, the comma, the question mark, AR, SK, BT and fraction bar DN.

**Signals used in other Radio Services**

Interrogatory di-di-dah-di-dah	.....	<u>INT</u>
Emergency Silence di-di-di-di-dah-dah	.....	<u>HM</u>
Executive Follows di-di-dah-di-di-dah	.....	<u>IX</u>
Break-in Signal dah-dah-dah-dah-dah	-----	<u>TTTTT</u>
Emergency Signal di-di-di-dah-dah-dah-di-di-dit	.....	<u>SOS</u>
Relay of Distress dah-di-di-dah-di-di-dah-di-dit	.....	<u>DDD</u>

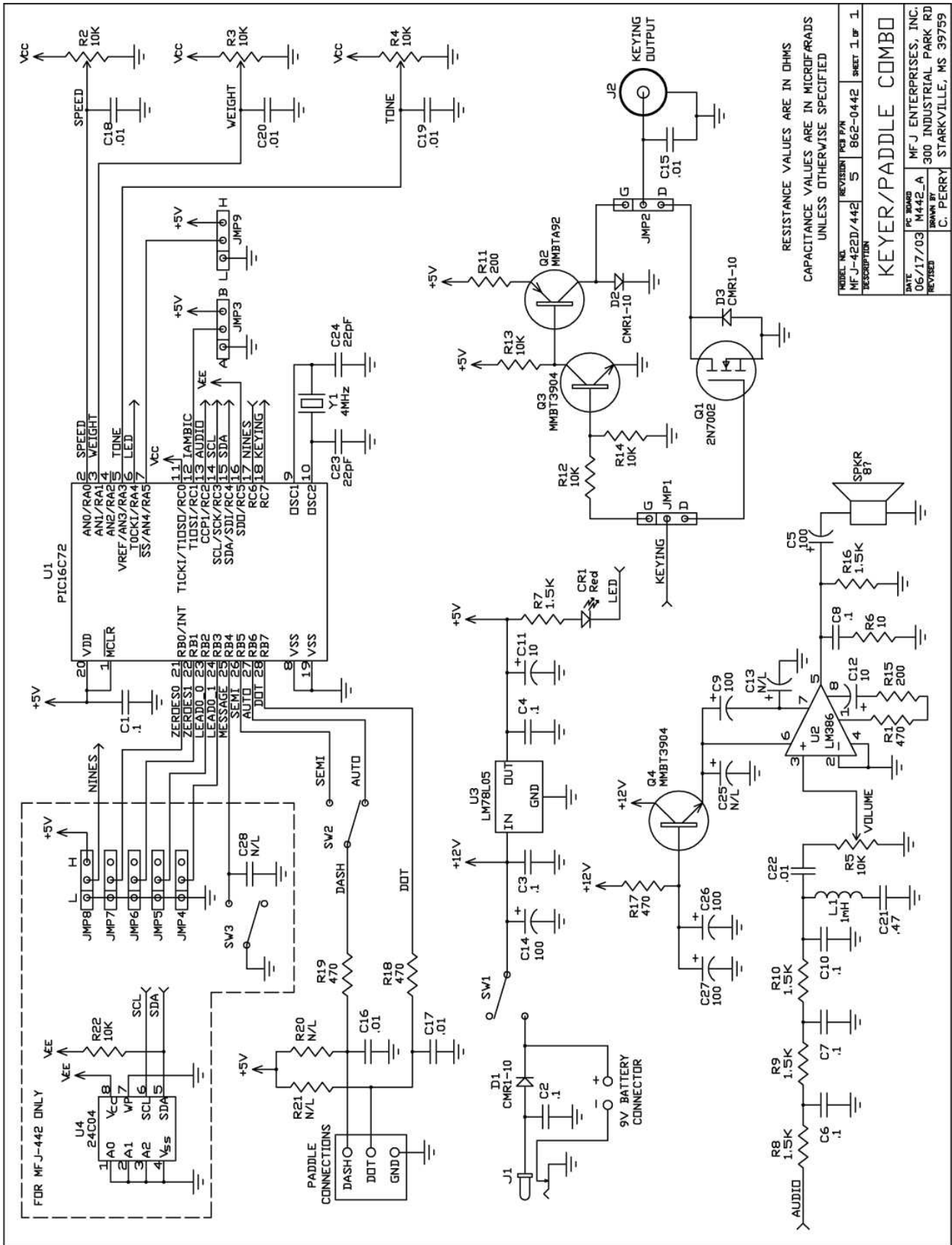

RESISTANCE VALUES ARE IN OHMS  
CAPACITANCE VALUES ARE IN MICROFARADS  
UNLESS OTHERWISE SPECIFIED

MODEL NO.	REVISION	PCB P/N	SHEET 1 OF 1
MFJ-422D/442	5	862-0442	
<b>KEYER/PADDLE COMBO</b>			
DATE	PC BOARD	MFJ ENTERPRISES, INC.	
06/17/03	M442-A	300 INDUSTRIAL PARK RD	
DESIGNED BY	DRAWN BY	C. PERRY	
REVISED		STARKVILLE, MS 39759	