

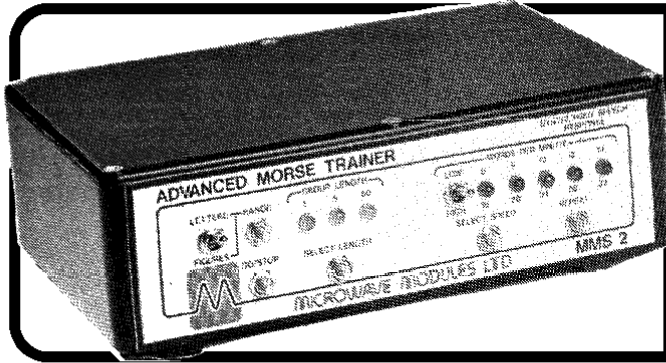

MICROWAVE MODULES LTD

ADVANCED MORSE TRAINER: MMS2



FEATURES

- COMPLETE SELF CONTAINED SPEAKING MORSE TRAINER FOR RECEPTION AND TRANSMISSION
- WIDE SPEED RANGE: 6-32 wpm
- LATEST STATE OF THE ART MICROPROCESSOR SPEECH SYNTHESIS SYSTEM
- VARIABLE GROUP LENGTH & SINGLE CHARACTER FACILITY
- SUITABLE FOR NOVICES AND EXPERIENCED OPERATORS ALIKE

SPECIFICATION

SPEED RANGE	: 6-32 wpm (6, 8, 10, 14, 16, 20, 24, 28, 32 wpm)
CHARACTER GROUP LENGTH	: One letter, Five letters or Fifty letters BEFORE TALKBACK
NUMBER OF LEARNING LEVELS	: Six
POWER REQUIREMENTS	: 9 to 13.8 Volts DC at 350 mA
POWER CONNECTOR	: 5 pin DIN (Pin 3 earth, Pin 5 positive)
AUDIO OUTPUT LEVEL	: 250 mW into 8 ohms
EXTERNAL SPEAKER CONNECTOR	: 3.5 mm socket
TAPE RECORDER CONNECTOR	: Phono Socket
MORSE KEY CONNECTOR	: 3.5 mm socket
WEIGHT	: 1 kg (2 lb 2 oz)
OVERALL SIZE	: 187 × 120 × 53 mm ($7\frac{3}{8} \times 4\frac{3}{4} \times 2\frac{1}{16}$)

DESCRIPTION

This advanced Morse Trainer, MMS2, is a natural development of our highly successful speech synthesised Morse Tutor, MMS1.

The MMS2 contains all the features of the MMS1, with the additional feature of speaking back the morse code keyed into the unit by the pupil. This invaluable feature allows the pupil to gain efficiency in both sending and receive Morse.

The unit represents a truly cost-effective means of reaching all the standards required in PostOffice, Maritime and amateur Morse Code examinations, without having to rely on a third party for instruction. A DC power supply 9 to 13.8 volts and a suitable morse key are the only requirements to enable full operation, and the relevant connections are made to the sockets located on the rear panel using the supplied plugs.

RECEPTION

To give this product maximum versatility, we have incorporated six learning levels so that it is a simple matter to become more proficient even after passing the Morse Test.

The six ranges are: LETTERS ONLY: A-F, A-M, A-U, A-Z; NUMBERS ONLY: 0-9; LETTERS & NUMBERS: 0-Z.

Also for each of these ranges the user can select: 1) One letter; 2) Five letters (One word); or 3) Fifty letters (Ten words) BEFORE TALKBACK.

In the 'fifty' mode a repeat facility is incorporated so that a double check may be made, and this is obtained by depressing the 'REPEAT' button.

In addition, a useful facility is provided in that continuous Morse can be sent to the pupil, and this is achieved by depressing the 'SELECT LENGTH' button until all three LEDs are extinguished. (No talkback in this mode.)

Morse speeds in the range 6-32 wpm are programmed into this unit. Speeds in the range 6-14 wpm are in 2 wpm increments and speeds in the range 16-32 wpm are in 4 wpm increments. Speed selection is made by depressing the 'SPEED SELECT' button located on the front panel. However, at speeds of 12 wpm or less, characters are sent at 12 wpm but the spacing is adjusted for the selected speed. In this way Morse rhythm will be instilled since this is the essence of good Morse rather than the dots and dashes approach.

TRANSMISSION

Selection of this mode is achieved by depressing the 'GO/STOP' button into the STOP position. The connection of a suitable Morse key to the socket marked 'KEY', located on the rear panel, will allow the pupil to send his own Morse into the unit for talkback. A mixture of letters and numbers may be sent together.

The 'SELECT LENGTH' button is utilised as follows:

In the single character position the MMS2 will talkback after each character has been completed.

However, in the 'five' position, the row of LEDs which in the receive mode serve to indicate the speed in use, now indicate the completion of each of the five characters as they are keyed into the unit. Talkback occurs only after the five characters have been completed, and at this time a tone will be heard followed by talkback of the five characters. Upon completion of this the MMS2 will then inform the pupil of the speed at which his Morse was sent.

In the 'fifty' position a similar routine occurs with the exception that talkback occurs only after fifty characters have been completed. A double check can be made in this mode due to the inclusion of a repeat facility. This is obtained by depressing the 'REPEAT' button. Also, correct inter-word spaces are recognised by the unit, and relevant gaps inserted when talkback occurs.

Should any character be sent in such a manner that it is unrecognisable, a low frequency tone will be heard.

A further useful feature is provided in that the internal sidetone oscillator can be used for practice purposes. This should be achieved by depressing the 'SELECT LENGTH' button until all three LEDs are extinguished.

GENERAL

The MMS2 contains an internal loudspeaker which may be supplemented by either headphones or an external loudspeaker, by connection to the socket marked 'EXTERNAL SPEAKER' located on the rear panel. The available audio output level at this socket is 250 mW.

In addition a tape recorder socket is also located on the rear panel so that recordings may be made at any time, without disabling the internal loudspeaker.

The incorporation of a crystal-controlled reference ensures totally accurate character and space, lengths and intervals, thereby producing a perfect rhythm. Housed in a highly durable black diecast case, the MMS2 utilises 2 microprocessors, 2 memory ICs and various other semiconductors and integrated circuits. All circuitry is constructed on two high quality glass-fibre printed circuit boards, and all plugs are supplied.

MICROWAVE MODULES

BROOKFIELD DRIVE, AINTREE, LIVERPOOL L9 7AN, ENGLAND

Telephone: 051-523 4011 Telex: 628608 MICRO G

INTERCONNECTIONS

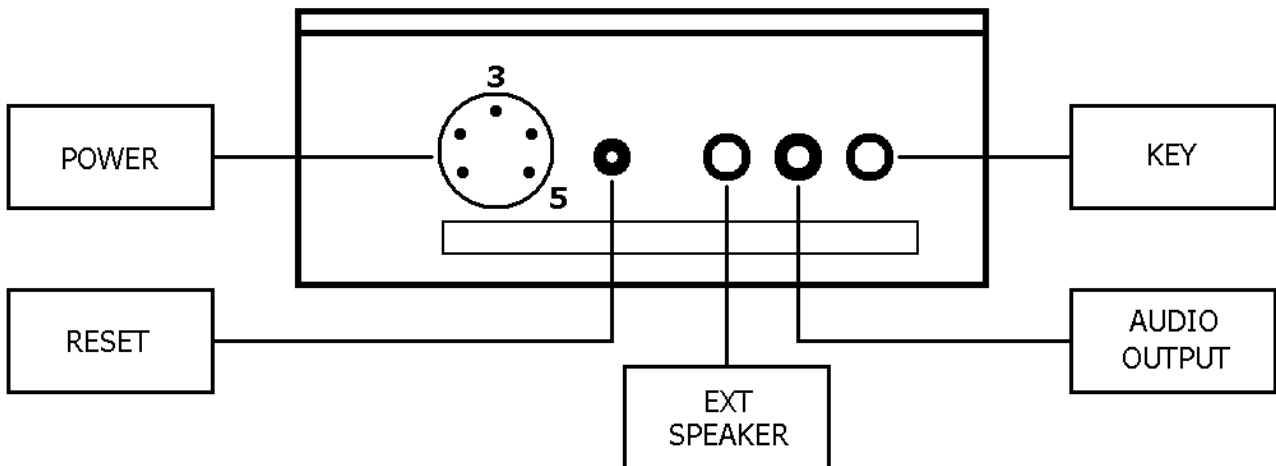

POWER CONNECTION

A 12 volt DC stabilized power supply is essential for reliable use. Such a power supply should be capable of providing up to 0.5 Amp.

Pin 3 of the socket is earth and pin 5 is positive. The unit is reverse polarity protected but care should be taken at all time to ensure correct polarity.

EXT SPEAKER

A 3.5 mm jack socket is located on the rear panel to allow the use of an external loudspeaker. Inserting a suitable plug into this socket will disable the internal speaker thereby allowing any 8 ohm speaker to be used. the available audio output at this socket is 250 mW.

AUDIO OUTPUT

This phono socket carries a audio output for connection to a tape or cassette recorder.

KEY

Any standard Morse or electronic keyer may be connected to the MMS2 as shown above.

OPERATION

THE FOLLOWING INSTRUCTIONS SHOULD BE FOLLOWED EXACTLY IN THE FIRST INSTANCE SO AS TO ENSURE AN ACCURATE DESCRIPTION OF THE PROGRAMMED SEQUENCES CONTAINED IN THE MORSETALKER.

1. The **LETTERS/FIGURES** switch must be in the **LETTER** position.
2. The **LOW/HIGH** speed must be in the **LOW** position.
 - a. Connect a suitable 12 volt DC power supply as described above.
 - b. Depress **RESET** button momentarily; the unit will respond with **A - Z**. The **GROUP LENGTH LED 1** will illuminate together with the **10 wpm** LED.

SPEED SELECTION

Depressing the **SELECT SPEED** button momentarily will advance the speed to 12 wpm and the corresponding LED will illuminate. Repeating this action will correspondingly select the next of the five slow speeds.

To select one of the high speeds (16 to 32 wpm) the user should switch the **LOW/HIGH** switch to the **HIGH** position and select a speed as before using the **SPEED SELECT** button.

Speeds in the range 6 – 14 wpm are in 2 wpm increments and speeds in the range 16 – 32 are in 4 wpm increments.

It should be noted that at any speed of 12 wpm or slower the characters are sent at 12 wpm but the spacing is adjusted to the selected speed.

RANGE SELECTION – LETTERS

On power-up the range A – Z is automatically selected. Depressing the **RANGE** button momentarily will reduce the range to A – F and the unit will confirm this by speech.

Repeating the above will select the next range, A – M. Depressing the **RANGE** button for a third time will select the range A – U. Depressing the **RANGE** button for a fourth time will select the original range A – Z.

RANGE SELECTION – FIGURES

Switching the **LETTERS/FIGURES** switch to **FIGURES** will reset the MMS2 to the **FIGURES** mode. The unit will respond with *0 - 9*.

Depressing the **RANGE** button momentarily will increase the range of the unit to the maximum, i.e. all letters and all figures and the unit will confirm this by saying *0 - Z*.

Returning the **LETTERS/FIGURES** switch to **LETTERS** reset the unit to the A - Z range.

GROUP LENGTH SELECTION

As described earlier, the MMS2 automatically resets to a group length of one when powered-up. This means that the unit will speak after each character has been sent in Morse code.

The group length may be increased to five characters by depressing the **SELECT LENGTH** button momentarily. In this mode five characters are sent in Morse code with correct inter-character spacing for the selected speed before the five characters are spoken back.

The group length may be further increased to fifty characters (10 groups each of five characters) by depressing the **SELECT LENGTH** button for a third time. In this mode fifty characters are sent in Morse code with correct inter-character and inter-word spacing for the selected speed, before the fifty characters are spoken.

Depressing the **SELECT LENGTH** button for a fourth time will extinguish all three LEDs which indicates that the internal speech synthesiser is disabled and in this mode continuous five character groups are sent in Morse code with no talkback.

GO/STOP

When the desired speed, group length and range selections have been made, depressing the **GO/STOP** button momentarily will set the unit operating. Whilst the unit is running it is not possible to re-select any of the above functions.

In order to re-select, the unit must first be stopped by depressing the **GO/STOP** button again.

However if the group length selected is fifty characters, then the unit will automatically stop on completion of each fifty character group.

At this time talkback may be repeated by depressing the REPEAT button momentarily, otherwise depressing the **GO/STOP** button will set the unit operating again.

TRANSMISSION

PLEASE NOTE THAT IN THIS MODE THE SPEED AND RANGE SELECTION FUNCTIONS ARE DISABLED.

SINGLE CHARACTER

To enter a single character, the user must ensure that the unit is in the STOP mode, by depressing the **RESET** button and that a suitable Morse key is connected to the socket on the rear panel marked **MORSE KEY**.

On completion of each single character the unit will respond with one of the following:

- a. The correct character (spoken).
- b. An 80 Hz tone which indicates non-recognition of the Morse.

SINGLE GROUP (5 CHARACTERS)

To enter five character groups the user must depress the **RESET** button momentarily followed by the **SELECT LENGTH** button. The selection of this mode will be indicated by the illumination of the **5** LED.

The user may now send five characters into the MMS2.

In this mode, the five red speed LEDs serve to indicate each of the five characters entered by advancing from left to right.

Upon completion a 400 Hz tone sounds, followed by talkback of the five characters and then the approximate speed of the Morse in words per minute. Please see note 1.

Another 400 Hz tone sounds to indicate the unit will then accept another five character group.

MULTIPLE GROUPS (50 CHARACTERS)

To enter fifty characters or multiple groups up to 50 characters the user must depress the **RESET** button momentarily, followed by two depressions of the **SELECT LENGTH** button. Correct selection will be indicated by the illumination of the **50** LED.

The user may now send multiple groups up to a maximum of 50 characters, including inter-group spaces. In this mode the five red speed LEDs serve to indicate each of the fifty characters entered by advancing from left to right and by cycling 10 times.

It is essential to complete all fifty characters.

Upon completion a 400 Hz tone sounds followed by the talkback of the Morse and then the approximate speed of the Morse in words per minute. Please see note 1. A second 400 Hz tone sounds.

The talkback may be repeated by depressing the **REPEAT** button momentarily.

Upon completion the unit will accept another fifty characters.

CONTINUOUS MORSE PRACTICE

To use the internal oscillator for practice purposes (no talkback), depress the **RESET** button followed by three depressions of the **SELECT LENGTH** button. This will be indicated by all three group length LEDs becoming extinguished.

NOTE 1

The unit will recognise Morse in the range 6 – 32 wpm. However, at speeds above 20 wpm the unit will respond by stating 20 wpm, regardless of the speed at which the Morse was sent.

IF AT ANY TIME IT IS REQUIRED TO REVERT TO A CLEAR OR RESET STATE, SIMPLY DEPRESS THE RESET BUTTON MOMENTARILY!